

IEC Fuses 5x20 low breaking capacity 5SF Fast Acting

Complying with IEC-127-2 Standard Sheet 2

250 VAC
FROM 0.08 TO 10 A

Dimensions

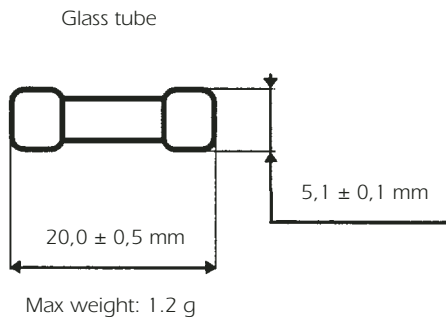

Basic Characteristics

Size	Rated Voltage	Rated Current	Breaking Capacity under 250 VAC	Max. power dissip	Max. Voltage drop	Designation	Reference Number	Catalog Number
mm	VAC	A	A	W	V			
5 x 20	250	0,08	35	0,39	0,93	250V 5SF 0,08 A 5 x 20	Z 090504	MI5SF25V0,08
		0,1		0,44	0,84	250V 5SF 0,1 A 5 x 20	A 090505	MI5SF25V0,1
		0,125		0,5	0,76	250V 5SF 0,125 A 5 x 20	B 090506	MI5SF25V0,125
		0,16		0,57	0,68	250V 5SF 0,16 A 5 x 20	C 090507	MI5SF25V0,16
		0,2		0,64	0,62	250V 5SF 0,2 A 5 x 20	D 090508	MI5SF25V0,20
		0,25		0,73	0,56	250V 5SF 0,25 A 5 x 20	E 090509	MI5SF25V0,25
		0,315		0,83	0,50	250V 5SF 0,315 A 5 x 20	F 090510	MI5SF25V0,315
		0,4		0,94	0,45	250V 5SF 0,4 A 5 x 20	G 090511	MI5SF25V0,40
		0,5		0,12	0,14	250V 5SF 0,5 A 5 x 20	H 090512	MI5SF25V0,50
		0,63		0,15	0,13	250V 5SF 0,63 A 5 x 20	J 090513	MI5SF25V0,63
		0,8		0,2	0,13	250V 5SF 0,8 A 5 x 20	K 090514	MI5SF25V0,80
		1		0,27	0,12	250V 5SF 1 A 5 x 20	L 090515	MI5SF25V1
		1,25		0,35	0,11	250V 5SF 1,25 A 5 x 20	M 090516	MI5SF25V1,25
		1,6		0,47	0,11	250V 5SF 1,6 A 5 x 20	N 090517	MI5SF25V1,6
		2		0,62	0,10	250V 5SF 2 A 5 x 20	P 090518	MI5SF25V2
		2,5		0,82	0,10	250V 5SF 2,5 A 5 x 20	Q 090519	MI5SF25V2,5
		3,15		1,08	0,09	250V 5SF 3,15 A 5 x 20	R 090520	MI5SF25V3,15
		4		1,43	0,09	250V 5SF 4 A 5 x 20	S 090521	MI5SF25V4
5	1,89	0,08	250V 5SF 5 A 5 x 20	T 090522	MI5SF25V5			
6,3	2,5	0,08	250V 5SF 6,3 A 5 x 20	V 090523	MI5SF25V6,3			
8*	3,3	0,08	250V 5SF 8 A 5 x 20	W 090524	MI5SF25V8			
10*	4,37	0,07	250V 5SF 10 A 5 x 20	X 090525	MI5SF25V10			

* and approval only.

* Non standard rating.

IEC Fuses 5x20 low breaking capacity 5SF Fast Acting

Melting time limits

Current	210 % x I _n	275 % x I _n	400 % x I _n	1 000 % x I _n
0,08 mA → 100 mA	30 min maxi	10 ms mini 500 ms maxi	3 ms mini 100 ms maxi	20 ms maxi
125 mA → 10 A	30 min maxi	50 ms mini 2 s maxi	10 ms mini 300 ms maxi	20 ms maxi

Time-current characteristics

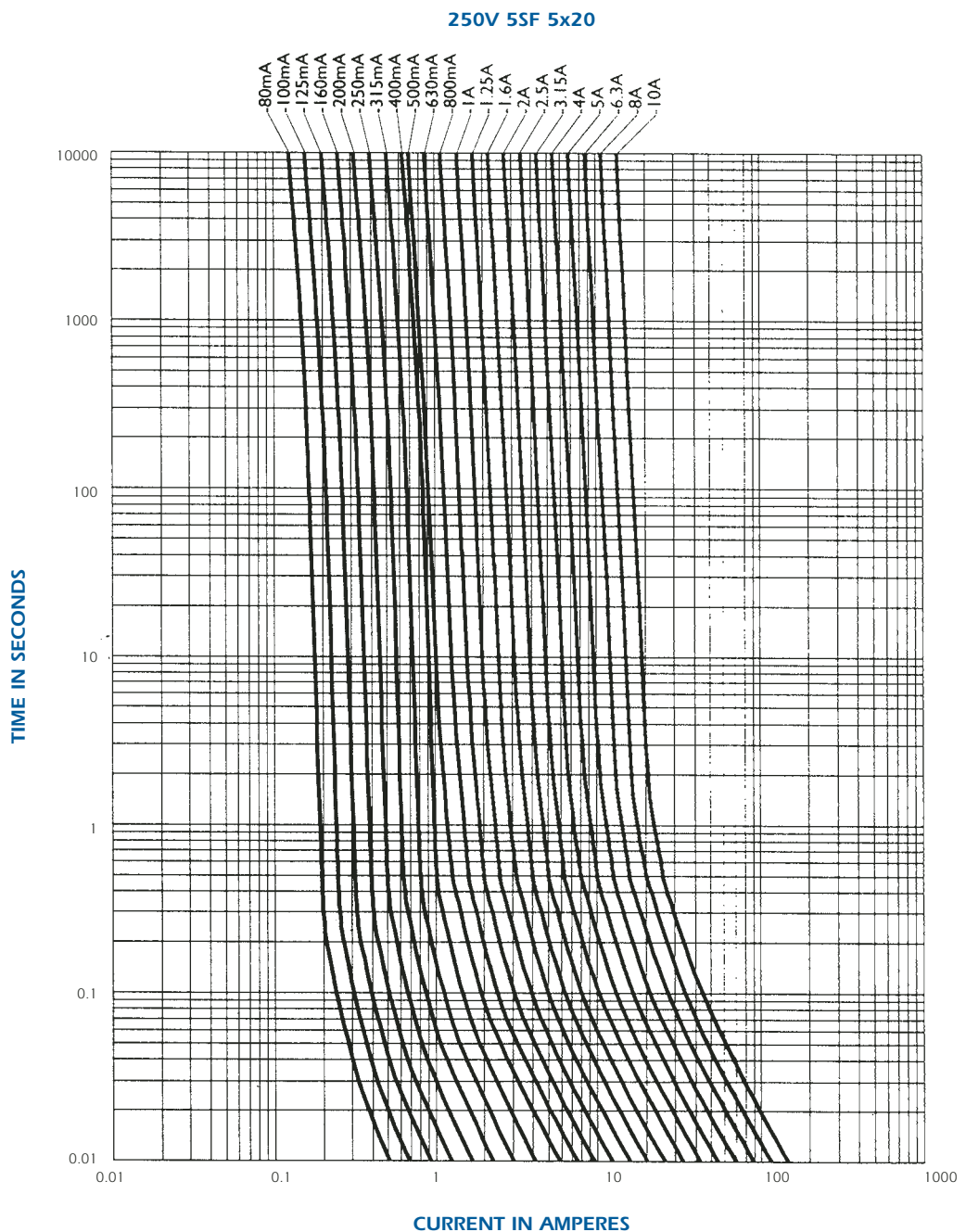

Packaging: in box of 1000 pieces.
in blister of 50 pieces.

IEC Fuses 5x20 low breaking capacity 5ST Time Lag

Complying with IEC-127-2 Standard Sheet 3

250 VAC
FROM 0.063 TO 10 A

Dimensions

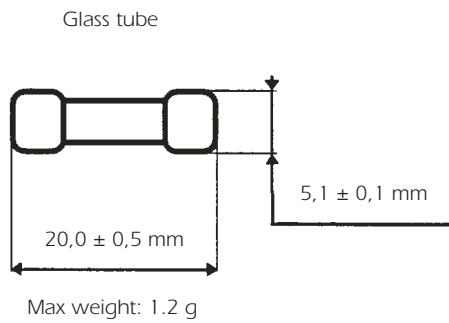

Basic Characteristics

Size	Rated Voltage	Rated Current	Breaking Capacity under 250 VAC	Max. power dissip	Max. Voltage drop	Designation	Reference Number	Catalog Number
mm	VAC	A	A	W	V			
5 x 20	250	0,063	35	0,28	2,77	250V 5ST 0,063 A 5 x 20	D 090531	MI5ST25V0,063
		0,08		0,29	2,24	250V 5ST 0,08 A 5 x 20	E 090532	MI5ST25V0,08
		0,1		0,30	1,82	250V 5ST 0,1 A 5 x 20	F 090533	MI5ST25V0,1
		0,125		0,30	1,47	250V 5ST 0,125 A 5 x 20	G 090534	MI5ST25V0,125
		0,16		0,31	1,19	250V 5ST 0,16 A 5 x 20	H 090535	MI5ST25V0,16
		0,2		0,32	0,97	250V 5ST 0,2 A 5 x 20	J 090536	MI5ST25V0,2
		0,25		0,32	0,78	250V 5ST 0,25 A 5 x 20	K 090537	MI5ST25V0,25
		0,315		0,33	0,63	250V 5ST 0,315 A 5 x 20	L 090538	MI5ST25V0,315
		0,4		0,34	0,51	250V 5ST 0,4 A 5 x 20	M 090539	MI5ST25V0,4
		0,5		0,34	0,42	250V 5ST 0,5 A 5 x 20	N 090540	MI5ST25V0,5
		0,63		0,18	0,17	250V 5ST 0,63 A 5 x 20	P 090541	MI5ST25V0,63
		0,8		0,20	0,15	250V 5ST 0,8 A 5 x 20	Q 090542	MI5ST25V0,8
		1		0,17	0,10	250V 5ST 1 A 5 x 20	R 090543	MI5ST25V1
		1,25		0,19	0,09	250V 5ST 1,25 A 5 x 20	S 090544	MI5ST25V1,25
		1,6		0,23	0,09	250V 5ST 1,6 A 5 x 20	T 090545	MI5ST25V1,6
		2		0,26	0,08	250V 5ST 2 A 5 x 20	V 090546	MI5ST25V2
		2,5		0,31	0,07	250V 5ST 2,5 A 5 x 20	W 090547	MI5ST25V2,5
		3,15		0,36	0,07	250V 5ST 3,15 A 5 x 20	X 090548	MI5ST25V3,15
		4		0,42	0,06	250V 5ST 4 A 5 x 20	Y 090549	MI5ST25V4
		5	0,49	0,06	250V 5ST 5 A 5 x 20	Z 090550	MI5ST25V5	
6,3	0,57	0,06	250V 5ST 6,3 A 5 x 20	A 090551	MI5ST25V6,3			
8*	0,8	0,06	250V 5ST 8 A 5 x 20	P 206070	MI5ST25V8			
10*	1	0,06	250V 5ST 10 A 5 x 20	Q 206071	MI5ST25V10			

* Non-standard ratings.

IEC Fuses 5x20 low breaking capacity 5ST Time Lag

Melting time limits

Current	210 % x In	275 % x In		400 % x In		1 000 % x In	
0,063 A → 0,1 A	2 min maxi	200 ms mini	10 s maxi	40 ms mini	3 s maxi	10 ms mini	300 ms maxi
0,125 A → 10 A	2 min maxi	600 ms mini	10 s maxi	150 ms mini	3 s maxi	20 ms mini	300 ms maxi

Time-current characteristics

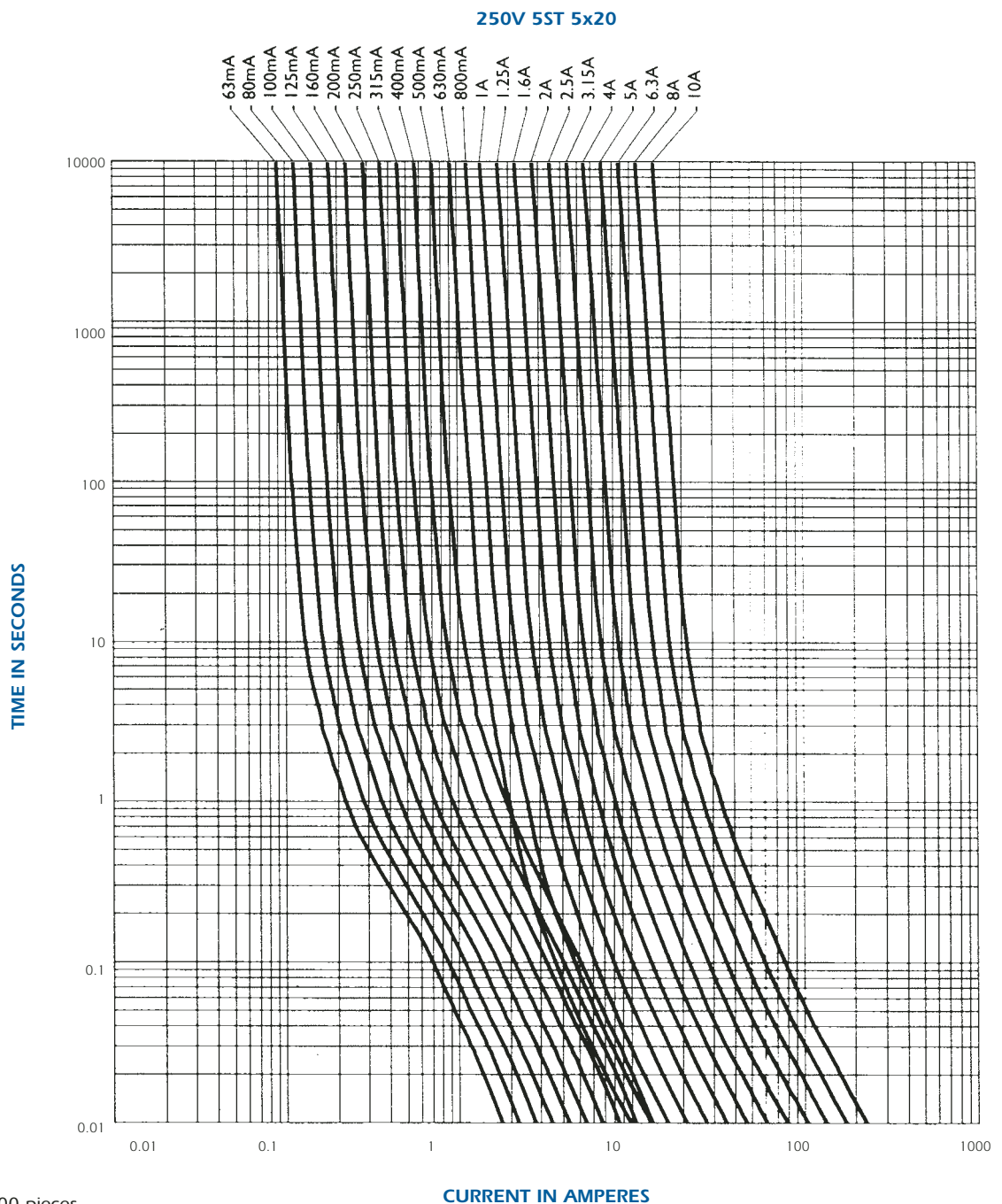

Packaging: in box of 1000 pieces.
in blister of 50 pieces.